

# Gas density indicator Model GDI-063

WIKA data sheet SP 60.21

## Applications

- Medium-voltage equipment
- Gas density monitoring of closed SF<sub>6</sub> gas tanks

## Special features

- Case and wetted parts from stainless steel
- On-site display of the pressure standardised to 20 °C
- Temperature-compensated and hermetically sealed, therefore no influence of temperature fluctuations, differences in level and atmospheric pressure fluctuations
- Traceability by serial number



Gas density indicator model GDI-063

## Description

Gas density is a crucial operating parameter for medium-voltage systems. If the required gas density is not present, safe operation of the plant cannot be guaranteed.

With WIKA gas density measuring instruments, changes of gas volumes can be determined reliably (e.g. leakages). Even under extreme environmental conditions.

### Numerous fields of application

The WIKA gas density indicator is hermetically sealed and temperature-compensated. Measured value fluctuations and misinterpretations caused by changes in either ambient temperature or atmospheric pressure are therefore prevented.

Via the on-site display, the pressure can be read directly on the instrument with reference to 20 °C.

## Gas density indicator

### Nominal size

63

### Calibration pressure $P_E$

To customer specification

### Accuracy specifications

- $\pm 1\%$  (min. 20 mbar) at an ambient temperature of  $+20\text{ }^\circ\text{C}$
- $\pm 2.5\%$  (min. 50 mbar) at an ambient temperature of  $-20 \dots +60\text{ }^\circ\text{C}$

### Scale range

Vacuum and overpressure range with measuring span  $\geq 1$  bar  
(at an ambient temperature of  $20\text{ }^\circ\text{C}$  and gaseous phase)

### Permissible ambient temperature

Operation:  $-20 \dots +60\text{ }^\circ\text{C}$  ( $-4 \dots +140\text{ }^\circ\text{F}$ ), gaseous phase  
Storage:  $-50 \dots +60\text{ }^\circ\text{C}$  ( $-58 \dots +140\text{ }^\circ\text{F}$ )

### Process connection

G  $\frac{1}{4}$  B per EN 837, lower mount  
Stainless steel, spanner flats 14 mm

Other connections and connection locations on request.

### Pressure element

Stainless steel, welded  
Gas-tight: leak rate  $\leq 1 \cdot 10^{-8}$  mbar  $\cdot$  l / s  
Test method: helium mass spectrometry

### Movement

Stainless steel  
Bimetal link (temperature compensation)

### Dial

Aluminium  
The scale range is subdivided into red, yellow and green ranges

### Pointer

Aluminium, black

### Case

Stainless steel, with gas filling  
Gas-tight: leak rate  $\leq 1 \cdot 10^{-5}$  mbar  $\cdot$  l / s  
Test method: Helium mass spectrometry

### Window

Selectable versions	
Option 1	Laminated safety glass
Option 2	Clear non-splintering plastic

### Ring

Bayonet ring, stainless steel, secured by means of 3 welding spots

### Permissible humidity

$\leq 90\%$  r. h. (non-condensing)

### Ingress protection

IP 65 per EN 60529 / IEC 60529

### Weight

approx. 160 g

### High-voltage test 100 %

2 kV, 50 Hz, 1s

## Dimensions in mm

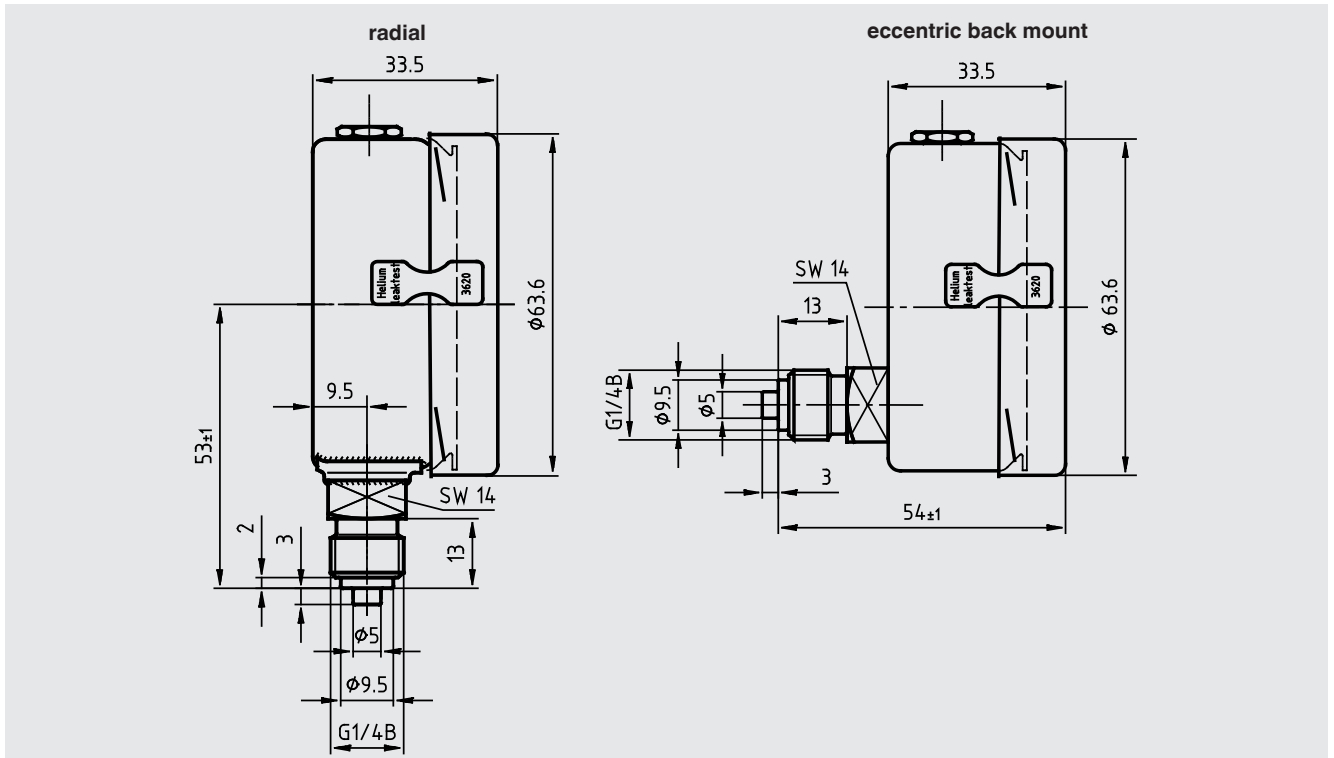

### Ordering information

Model / Process connection / Pressure unit / Measuring range / Filling pressure / Gas mixture / Options

© 2015 WIKA Alexander Wiegand SE & Co. KG, all rights reserved.  
The specifications given in this document represent the state of engineering at the time of publishing.  
We reserve the right to make modifications to the specifications and materials.

